

---

# **ELECTRIC CREPE MAKER MACHINE**

## **Manuel**

ECM-1、ECM-2

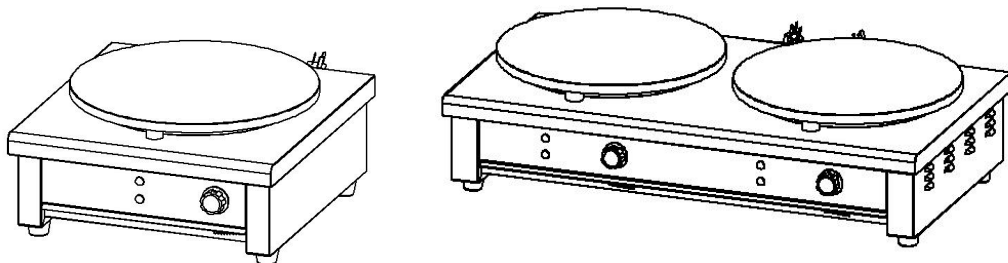

---

## I . Introduction:

ECM-1. ECM-2 series of electric crepe machine is one of the new electrometer products designed and developed by us, It adopts foreign advanced technology, international popular style, made by good quality stainless steel, tried and true. The plate is perfect as it is processed with special non-sticky technology. Main Body, made of the stainless steel, luxurious, good-looking and durable. With easy control and easy maintain function, it is the best choice for frying cakes, eggs, dumpling in food filed.

## II . Operating Instruction :

Place the machine in flat platform , power wire should be connected to the Leakage Circuit Switches (Leakage rated current 30mA ). Before use , please check whether the voltage of power switch and fuse are in conformity with the request of the machine' s power. the body must be earth properly. It is forbidden to put the tinder and explosive object near the machine, And keep it in the environment with the superior ventilation system. The temperature around should be less than 50°C.

## III. Operating Steps :

1. Put through the power, green light is on, adjust the thermostat to a proper temperature, machine starts to heat when the working indication light (orange) is on.
2. Warm up the plate to proper temperature , then start to fry .
3. To lengthen service life , and avoid accident , dry-burning is not permitted.

## IV. Technical Specification :

Model	Plates Diameter	Power	Voltage	Frequency	Dimension(cm)	Net Weight
ECM-1	400MM	3KW	220-240V	50HZ	45*47*22	18KG
ECM-2	2*400MM	3KW+3KW	220-240V	50HZ	88*47*24	36KG

---

## V. Circuit Diagram:

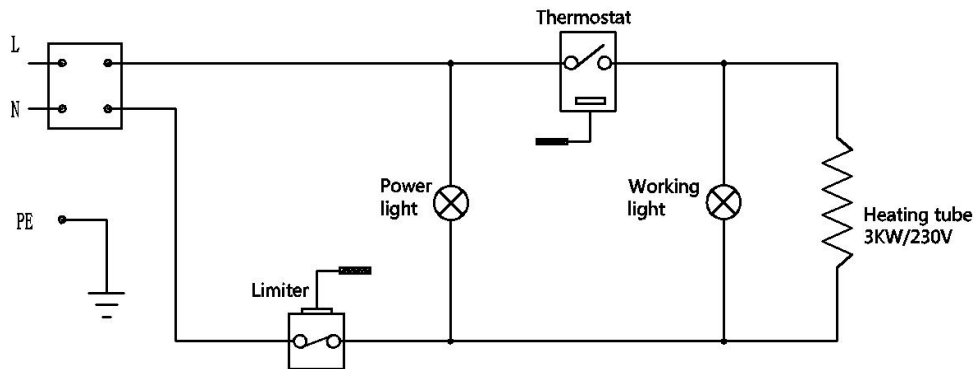

## VI. Notice :

1. Power should be connected to the ground firmly
2. Maybe ten minute for warm up after the machine start up .
3. Don not touch the plate and its surface around by hand while the machine is heating , which is to avoid burnt .
4. For better frying effect , do please do not scratch the plate .
5. All cleaning work should be carried on after the machine is cold

## VII. Warning :

1. As the machine will be easily cause creep-age by wet, so “ Cleaned by water column “ and Dipped in the water for cleaning “ is not allowed .
2. For safe , if the power wire damaged , manufacturer or professional electrician will be asked to change the wire .
3. Make sure dry hands .
4. Make sure insulation between the power switch, plugs , thermostat with hands .

## VIII. Exploded View:

---

No	Name	Quantity	
		ECM-1	ECM-2
1	Crepe maker plate	1	2
2	Heater	1	2
3	Thermal insulation board	1	2
4	Press plate	3	6
5	Cotton cover plate	1	2
6	Lead screw M8×60	3	6
7	Screw M8	3	6
8	Body housing	1	1
9	Terminal board	1	2
10	New cable head	1	2
11	Power cable	1	2
12	320°C Cut out	1	2
13	Indicator light (yellow)	1	2
14	Indicator light (green)	1	2
15	Knob	1	2
16	300°C Thermostat	1	2
17	Tray	1	1
18	Base Board	2	2
19	Rubber feet	4	4

